

Stainless Steel Valves

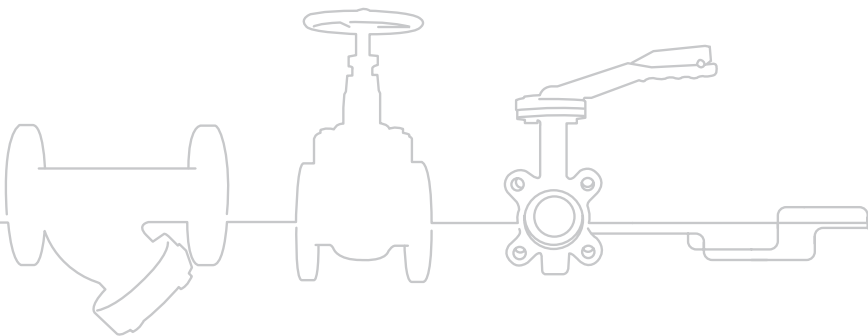

Product Information



PN69 Stainless Steel 1 Piece Ball Valve

Features

- Screwed BSP Taper
- RPTFE (15%) Seats
- PTFE Seals
- Reduced Bore
- PN69 Rated
- Locking Device



Pressure / Temperature

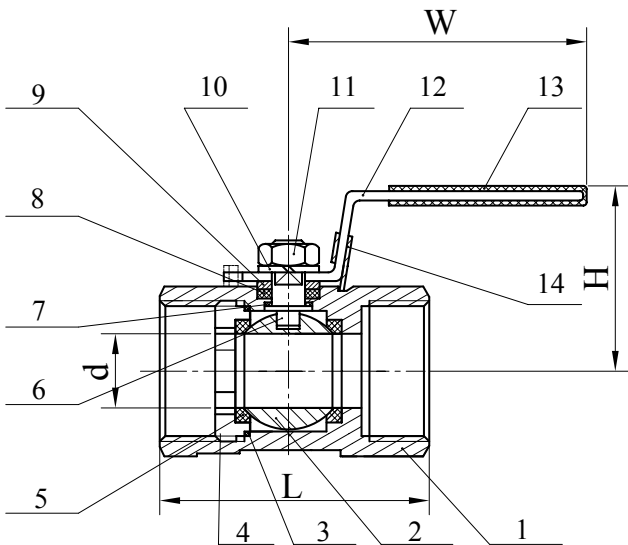
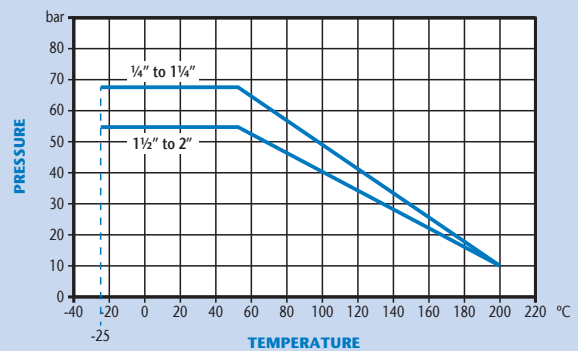

DN	1/4"	3/8"	1/2"	3/4"	1"	1 1/4"	1 1/2"	2"
d	5	6.8	9.5	12.7	16	20	25	32
L	40	45	56	59	71	76	85	99
H	32	33	43	45	48	58.3	67	74
W	67	67	93	93	93	106	128	128
Torque	4	4	6	6	8	10	14	15
Kgs	0.09	0.12	0.19	0.28	0.39	0.58	0.85	1.35

Technical Data

Max Pressure 69 Bar (1/4"-1 1/4") 55 Bar (1 1/2"-2")
 Working Temperature -25°C to +200°C

N.	Part Name	Materials
1	Body	CF8M
2	Ball	Stainless Steel 316
3	Body Gasket	PTFE
4	Cap	CF8M
5	Ball Seat	R-PTFE (15%)
6	Stem	Stainless Steel 316
7	Thrust Washer	PTFE
8	Stem Packing	PTFE
9	Washer	Stainless Steel 304
10	Spring Washer	Stainless Steel 304
11	Nut	Stainless Steel 304
12	Handle	Stainless Steel 304
13	Handle Cover	Plastic
14	Lock Device	Stainless Steel 304

Dimensions in mm

This data sheet is designed as a guide and should not be regarded as wholly accurate in every detail. We reserve the right to amend the specification of any product without notice.

PN82 Stainless Steel 2 Piece Ball Valve

Features

- Screwed BSP Taper
- RPTFE (15%) Seats
- PTFE Seals
- Full Bore
- PN82 Rated
- Locking Device

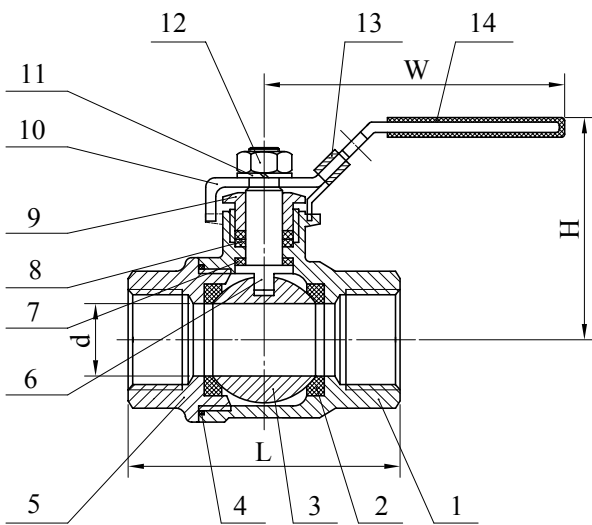

Pressure / Temperature

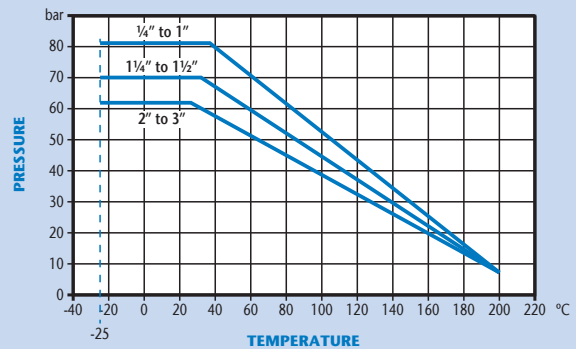

DN	1/4"	3/8"	1/2"	3/4"	1"	1 1/4"	1 1/2"	2"	2 1/2"	3"
d	11.5	12.5	15	20	25	32	40	50	65	76
L	49	49	57	64	77	90	105	125	153	172
H	54	54	56	65	70	75	93	99	123	140
W	105	105	105	118	150	150	182	182	254	254
Torque	4	4	5	8	10	14	18	25	48	75
Kgs	0.23	0.23	0.24	0.45	0.65	1.05	1.70	2.61	5.01	7.61

Technical Data

Max Pressure 82 Bar (1/4"-1") 69 Bar (1 1/4"-1 1/2") 62 Bar (2"-3")
 Working Temperature -25°C to +200°C

N.	Part Name	Material
1	Body	CF8M
2	Ball Seat	R-PTFE (15%)
3	Ball	Stainless Steel 316
4	Body Gasket	PTFE
5	Cap	CF8M
6	Stem	Stainless Steel 316
7	Thrust Washer	PTFE
8	Stem Packing	PTFE
9	Gland Nut	Stainless Steel 304
10	Handle	Stainless Steel 304
11	Spring Washer	Stainless Steel 304
12	Nut	Stainless Steel 304
13	Lock Device	Stainless Steel 304
14	Handle Cover	Plastic

Dimensions in mm

This data sheet is designed as a guide and should not be regarded as wholly accurate in every detail. We reserve the right to amend the specification of any product without notice.

PN82 Stainless Steel 2 Piece Ball Valve

Features

- Screwed BSP Parallel
- RPTFE (15%) Seats
- PTFE Seals
- Full Bore
- PN82 Rated
- Locking Device

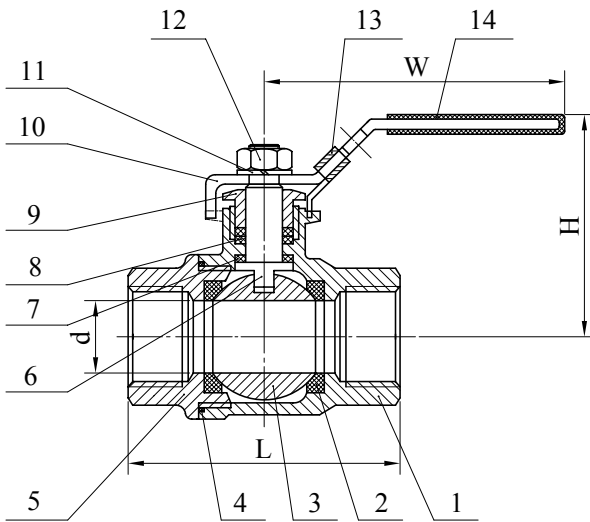

Pressure / Temperature

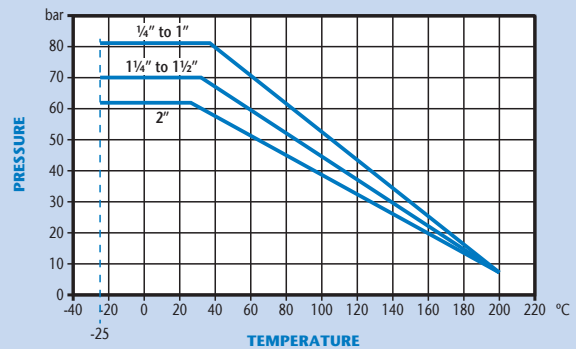

DN	1/4"	3/8"	1/2"	3/4"	1"	1 1/4"	1 1/2"	2"
d	11.5	12.5	15	20	25	32	40	50
L	49	49	57	64	77	90	105	125
H	54	54	56	65	70	75	93	99
W	105	105	105	118	150	150	182	182
Torque	4	4	5	8	10	14	18	25
Kgs	0.23	0.23	0.24	0.45	0.65	1.05	1.70	2.61

Technical Data

Max Pressure 82 Bar (1/4"-1") 69 Bar (1 1/4"-1 1/2") 62 Bar (2"-3")
 Working Temperature -25°C to +200°C

N.	Part Name	Material
1	Body	CF8M
2	Ball Seat	R-PTFE (15%)
3	Ball	Stainless Steel 316
4	Body Gasket	PTFE
5	Cap	CF8M
6	Stem	Stainless Steel 316
7	Thrust Washer	PTFE
8	Stem Packing	PTFE
9	Gland Nut	Stainless Steel 304
10	Handle	Stainless Steel 304
11	Spring Washer	Stainless Steel 304
12	Nut	Stainless Steel 304
13	Lock Device	Stainless Steel 304
14	Handle Cover	Plastic

Dimensions in mm

This data sheet is designed as a guide and should not be regarded as wholly accurate in every detail. We reserve the right to amend the specification of any product without notice.

PN82 Stainless Steel 2 Piece Ball Valve

Features

- Screwed NPT
- RPTFE (15%) Seats
- PTFE Seals
- Full Bore
- PN82 Rated
- Locking Device



Pressure / Temperature

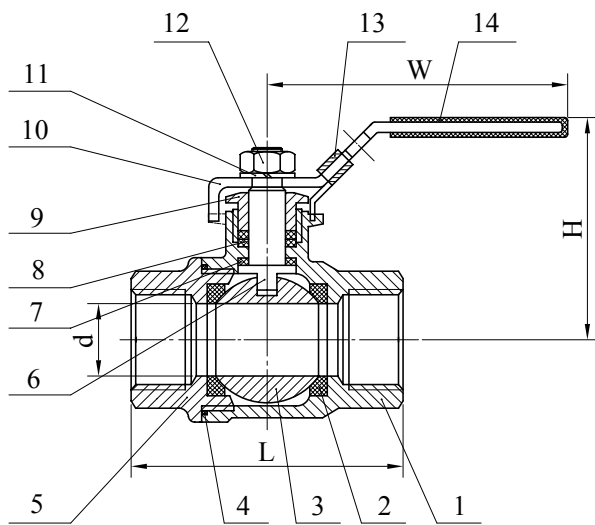
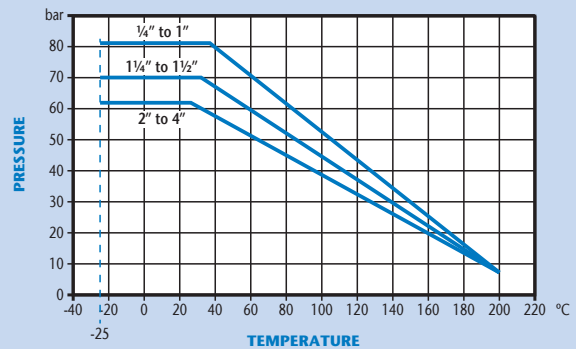

DN	1/4"	3/8"	1/2"	3/4"	1"	1 1/4"	1 1/2"	2"
d	11.5	12.5	15	20	25	32	40	50
L	49	49	57	64	77	90	105	125
H	54	54	56	65	70	75	93	99
W	105	105	105	118	150	150	182	182
Torque	4	4	5	8	10	14	18	25
Kgs	0.23	0.23	0.24	0.45	0.65	1.05	1.70	2.61

Technical Data

Max Pressure 82 Bar (1/4"-1") 69 Bar (1 1/4"-1 1/2") 62 Bar (2"-3")
 Working Temperature -25°C to +200°C

N.	Part Name	Material
1	Body	CF8M
2	Ball Seat	R-PTFE (15%)
3	Ball	Stainless Steel 316
4	Body Gasket	PTFE
5	Cap	CF8M
6	Stem	Stainless Steel 316
7	Thrust Washer	PTFE
8	Stem Packing	PTFE
9	Gland Nut	Stainless Steel 304
10	Handle	Stainless Steel 304
11	Spring Washer	Stainless Steel 304
12	Nut	Stainless Steel 304
13	Lock Device	Stainless Steel 304
14	Handle Cover	Plastic

Dimensions in mm

This data sheet is designed as a guide and should not be regarded as wholly accurate in every detail. We reserve the right to amend the specification of any product without notice.

PN82 Stainless Steel 3 Piece Ball Valve

Features

- Screwed BSP Taper
- RPTFE (15%) Seats
- PTFE Seals
- Full Bore
- PN82 Rated
- Locking Device

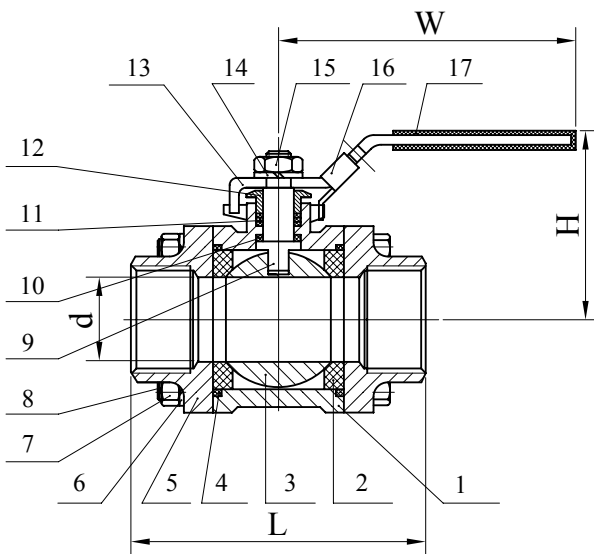

Pressure / Temperature

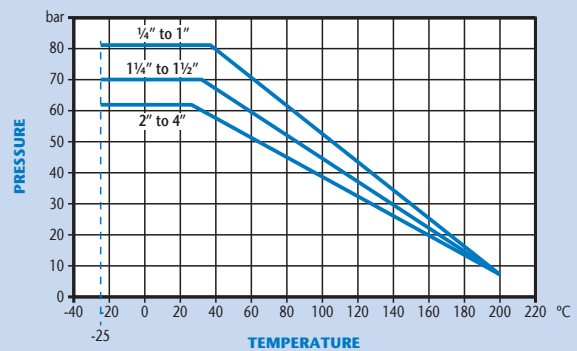

DN	1/4"	3/8"	1/2"	3/4"	1"	1 1/4"	1 1/2"	2"	2 1/2"	3"
d	11	12.5	15	20	25	32	40	50	65	80
L	50	60	75	80	90	110	120	140	185	205
H	51	51	53	60	75	80	88	95	121	135
W	105	105	118	118	150	150	182	182	254	254
Torque	4	4	5	8	10	14	18	25	48	75
Kgs	0.40	0.42	0.45	0.73	1.04	1.65	2.43	3.52	7.14	11.85

N.	Part Name	Material
1	Body	CF8M
2	Ball Seat	R-PTFE (15%)
3	Ball	Stainless Steel 316
4	Body Gasket	PTFE
5	Cap	CF8M
6	Spring Washer	Stainless Steel 304
7	Nut	Stainless Steel 304
8	Bolt	Stainless Steel 304
9	Stem	Stainless Steel 316
10	Thrust Washer	PTFE
11	Stem Packing	PTFE
12	Gland Nut	Stainless Steel 304
13	Handle	Stainless Steel 304
14	Spring Washer	Stainless Steel 304
15	Nut	Stainless Steel 304
16	Lock Device	Stainless Steel 304
17	Handle Cover	Plastic

Technical Data

Max Pressure 82 Bar (1/4"-1") 69 Bar (1 1/4"-1 1/2") 62 Bar (2"-4")
 Working Temperature -25°C to +200°C

Dimensions in mm

This data sheet is designed as a guide and should not be regarded as wholly accurate in every detail. We reserve the right to amend the specification of any product without notice.

PN82 Stainless Steel 3 Piece Ball Valve

Features

- Socket Weld Ends
- RPTFE (15%) Seats
- PTFE Seals
- Full Bore
- PN82 Rated
- Locking Device



Pressure / Temperature

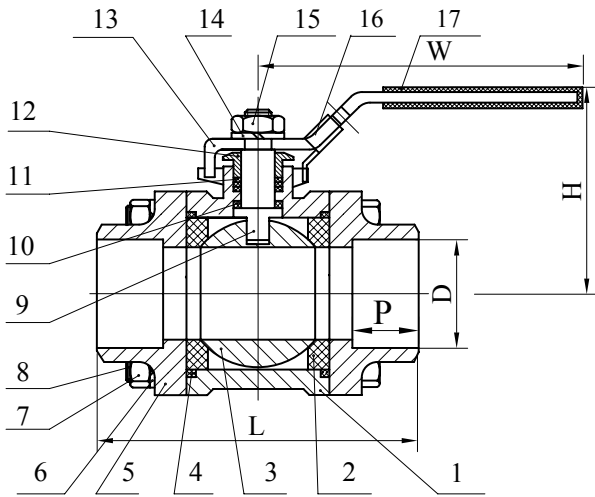
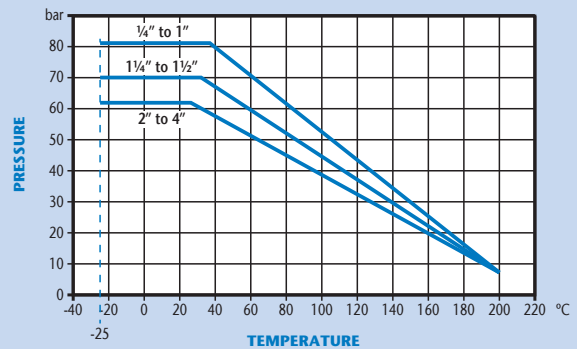

DN	1/4"	3/8"	1/2"	3/4"	1"	1 1/4"	1 1/2"	2"	2 1/2"	3"
D	14	17.6	21.7	27.3	34.1	42.8	48.7	61	77	90
P	10	10	10	13	13	13	13	16	16	16
L	50	60	75	80	90	110	120	140	185	205
H	51	51	53	60	75	80	88	95	121	135
W	105	105	118	118	150	150	182	182	254	254
Torque	4	4	5	8	10	14	18	25	48	75
Kgs	0.38	0.40	0.41	0.71	0.95	1.64	2.36	3.42	6.88	11.50

Technical Data

Max Pressure 82 Bar (1/4"-1") 69 Bar (1 1/4"-1 1/2") 62 Bar (2"-4")
 Working Temperature -25°C to +200°C

N.	Part Name	Material
1	Body	CF8M
2	Ball Seat	R-PTFE (15%)
3	Ball	Stainless Steel 316
4	Body Gasket	PTFE
5	Cap	CF8M
6	Spring Washer	Stainless Steel 304
7	Nut	Stainless Steel 304
8	Bolt	Stainless Steel 304
9	Stem	Stainless Steel 316
10	Thrust Washer	PTFE
11	Stem Packing	PTFE
12	Gland Nut	Stainless Steel 304
13	Handle	Stainless Steel 304
14	Spring Washer	Stainless Steel 304
15	Nut	Stainless Steel 304
16	Locking Device	Stainless Steel 304
17	Handle Cover	Plastic

Dimensions in mm

This data sheet is designed as a guide and should not be regarded as wholly accurate in every detail. We reserve the right to amend the specification of any product without notice.

PN82 Carbon Steel 3 Piece Ball Valve

Features

- Screwed BSP Taper
- RPTFE (15%) Seats
- PTFE Seals
- Full Bore
- PN82 Rated
- Locking Device



Pressure / Temperature

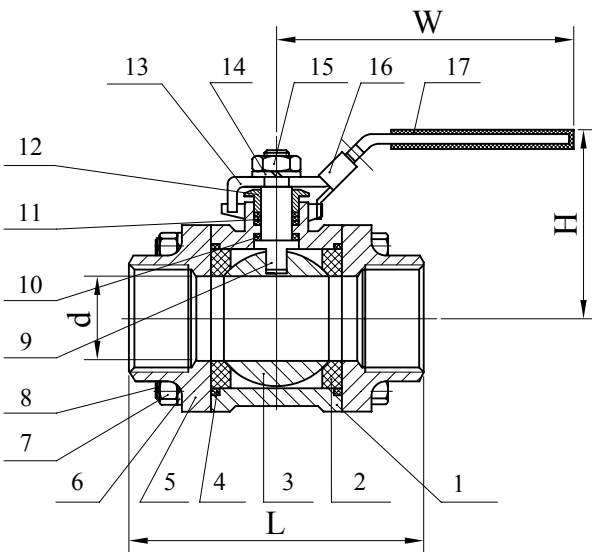
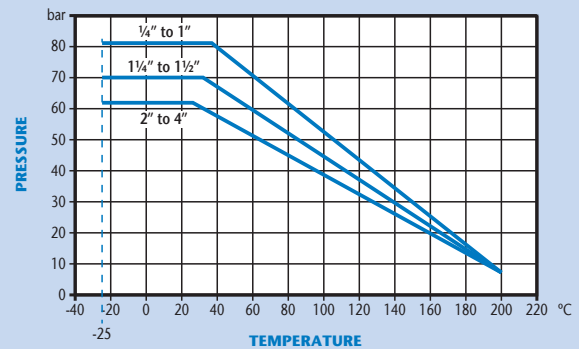

DN	1/4"	3/8"	1/2"	3/4"	1"	1 1/4"	1 1/2"	2"	2 1/2"	3"
d	11	12.5	15	20	25	32	40	50	65	80
L	50	60	75	80	90	110	120	140	185	205
H	51	51	53	60	75	80	88	95	121	135
W	105	105	118	118	150	150	182	182	254	254
Torque	4	4	5	8	10	14	18	25	48	75
Kgs	0.40	0.42	0.45	0.73	1.04	1.65	2.43	3.52	7.14	11.85

N.	Part Name	Material
1	Body	Carbon Steel
2	Ball Seat	R-PTFE (15%)
3	Ball	Stainless Steel 316
4	Body Gasket	PTFE
5	Cap	Carbon Steel
6	Spring Washer	Stainless Steel 304
7	Nut	Stainless Steel 304
8	Bolt	Stainless Steel 304
9	Stem	Stainless Steel 316
10	Thrust Washer	PTFE
11	Stem Packing	PTFE
12	Gland Nut	Stainless Steel 304
13	Handle	Stainless Steel 304
14	Spring Washer	Stainless Steel 304
15	Nut	Stainless Steel 304
16	Lock Device	Stainless Steel 304
17	Handle Cover	Plastic

Technical Data

Max Pressure 82 Bar (1/4"-1") 69 Bar (1 1/4"-1 1/2") 62 Bar (2"-4")
 Working Temperature -25°C to +200°C

Dimensions in mm

This data sheet is designed as a guide and should not be regarded as wholly accurate in every detail. We reserve the right to amend the specification of any product without notice.

PN82 Stainless Steel 3 Piece Ball Valve ISO5211

Features

- Screwed BSP Taper
- RPTFE (15%) Seats
- PTFE Seals
- Full Bore
- Locking Device
- ISO5211 Direct Mount
- PN82 Rated

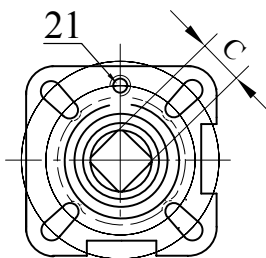
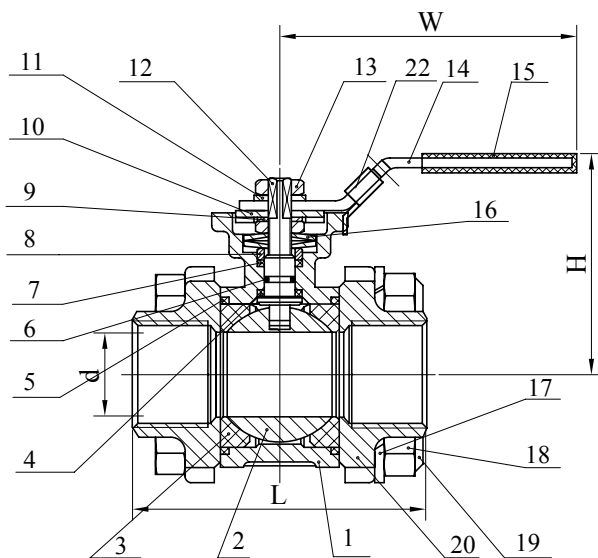

ISO5211

* Torque - Raw torque with no safety added

Technical Data

Max Pressure 82 Bar (1/4"-1") 69 Bar (1 1/4"-1 1/2") 62 Bar (2"-4")

Working Temperature -25°C to +200°C

Pressure / Temperature

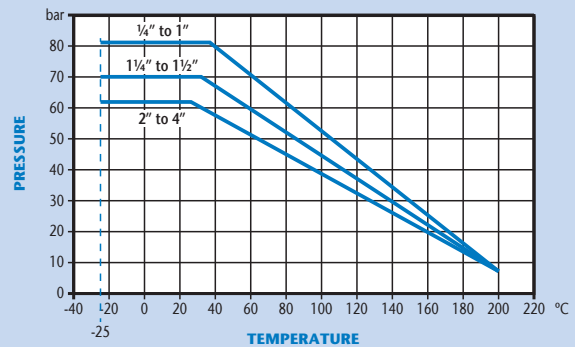

DN	1/4"	3/8"	1/2"	3/4"	1"	1 1/4"	1 1/2"	2"	2 1/2"	3"	4"
d	11	12.5	15	20	25	32	40	50	65	80	100
L	50	60	75	80	90	110	120	140	185	205	240
H	59	59	63	70	74	88	94	102	140	153	166
W	120	120	120	140	140	204	204	204	255	255	302
C	9	9	9	9	11	11	14	14	17	17	17
ISO5211	F03	F03	F03/F04	F04/F05	F04/F05	F05/F07	F05/F07	F05/F07	F07/F010	F07/F010	F07/F010
Torque	4	4	5	8	10	14	18	25	48	75	110
Kgs	0.46	0.48	0.51	0.89	1.27	2.04	3.00	3.80	7.80	12.4	20.8

N.	Part Name	Material
1	Body	CF8M
2	Ball	Stainless Steel 316
3	Ball Seat	R-PTFE (15%)
4	Thrust Washer	PTFE
5	Body Gasket	PTFE
6	O-Ring	Viton
7	Stem Packing	PTFE
8	Gland	Stainless Steel 304
9	Tab Washer	Stainless Steel 304
10	Stopper	Stainless Steel 304
11	Spring Washer	Stainless Steel 304
12	Stem	Stainless Steel 316
13	Nut	Stainless Steel 304
14	Handle	Stainless Steel 304
15	Handle Cover	Plastic
16	Belleville Washer	Stainless Steel 301
17	Spring Washer	Stainless Steel 304
18	Nut	Stainless Steel 304
19	Bolt	Stainless Steel 304
20	Cap	CF8M
21	Stop Pin	Stainless Steel 304
22	Locking Device	Stainless Steel 304

Dimensions in mm

This data sheet is designed as a guide and should not be regarded as wholly accurate in every detail. We reserve the right to amend the specification of any product without notice.

PN82 Stainless Steel 3 Piece Ball Valve ISO5211

Features

- Screwed BSP Taper
- RPTFE (15%) Seats
- PTFE Seals
- Full Bore
- Locking Device
- ISO5211 Direct Mount
- PN82 Rated

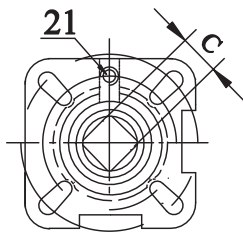
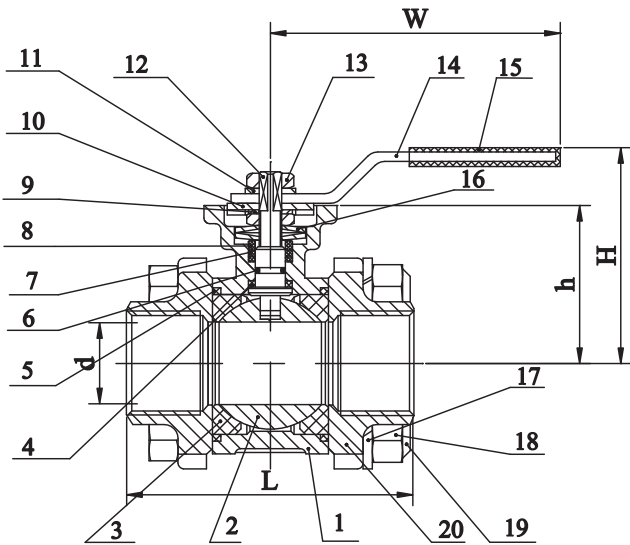

ISO5211

* Torque - Raw torque with no safety added

Technical Data

Max Pressure 82 Bar (1/4"-1") 69 Bar (1 1/4"-1 1/2") 62 Bar (2"-4")
Working Temperature -25°C to +200°C

Pressure / Temperature

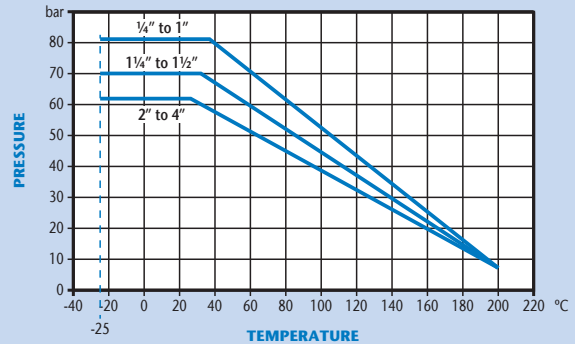

DN	1/4"	3/8"	1/2"	3/4"	1"	1 1/4"	1 1/2"	2"	2 1/2"	3"	4"
d	11	12.5	15	20	25	32	40	50	65	80	100
L	50	60	75	80	90	110	120	140	185	205	240
H	59	59	70	78	87	98	104	112	140	153	166
h	32.5	32.5	42.0	50.0	58.0	64.0	69.5	78.0	100	112.5	112.5
W	115	115	117	134	134	203	203	203	255	255	302
C	9	9	9	11	11	14	14	14	17	17	17
ISO5211	F03	F03	F03/F04	F04/F05	F04/F05	F05/F07	F05/F07	F05/F07	F07/F010	F07/F010	F07/F010
Torque	4	4	5	8	10	14	18	25	48	75	110
Kgs	0.46	0.48	0.51	0.89	1.27	2.04	3.00	3.80	7.80	12.4	20.8

N.	Part Name	Material
1	Body	CF8M
2	Ball	Stainless Steel 316
3	Ball Seat	R-PTFE (15%)
4	Thrust Washer	PTFE
5	Body Gasket	PTFE
6	O-Ring	Viton
7	Stem Packing	PTFE
8	Gland	Stainless Steel 304
9	Tab Washer	Stainless Steel 304
10	Stopper	Stainless Steel 304
11	Spring Washer	Stainless Steel 304
12	Stem	Stainless Steel 316
13	Nut	Stainless Steel 304
14	Handle	Stainless Steel 304
15	Handle Cover	Plastic
16	Belleville Washer	Stainless Steel 301
17	Spring Washer	Stainless Steel 304
18	Nut	Stainless Steel 304
19	Bolt	Stainless Steel 304
20	Cap	CF8M
21	Stop Pin	Stainless Steel 304

Dimensions in mm

This data sheet is designed as a guide and should not be regarded as wholly accurate in every detail. We reserve the right to amend the specification of any product without notice.

PN16/40 Stainless Steel Flanged Ball Valve

Features

- Flanged PN16/PN40
- PN40 Rated 1/2" to 2"
- PN16 Rated 2 1/2" to 4"
- RPTFE (15%) Seats
- PTFE/Viton Stem Seals
- Full Bore
- ISO 5211 Direct Mount
- Fire Safe Design

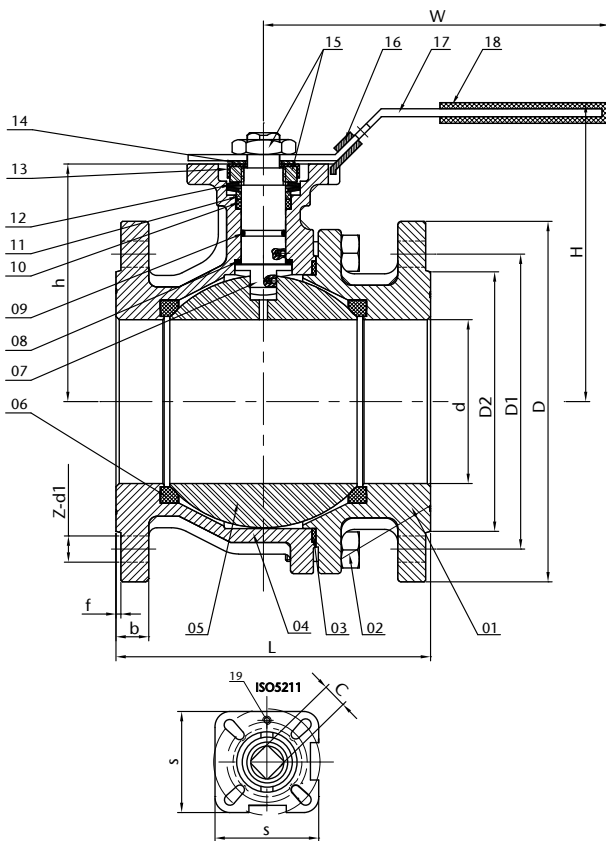

Pressure / Temperature

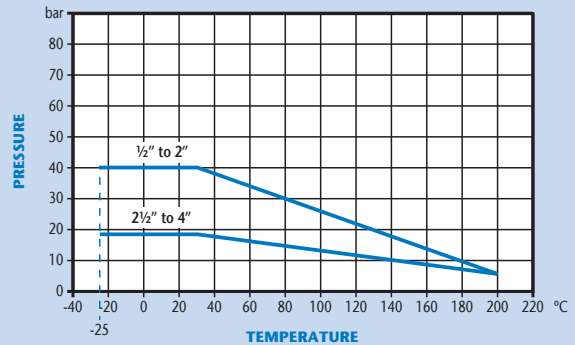

DN	1/2"	3/4"	1"	1 1/4"	1 1/2"	2"	2 1/2"	3"	4"
d	15	20	25	32	40	50	65	80	100
L	115	120	125	130	140	150	170	180	190
D	95	105	115	140	150	165	185	200	220
D1	65	75	85	100	110	125	145	160	180
D2	45	58	68	78	88	102	122	138	158
b	16	18	18	18	18	20	18	20	20
f	2	2	2	2	3	3	3	3	3
H	82	87	90	100	105	125	142	155	168
W	120	120	160	160	200	200	255	255	300
C	9	9	11	11	14	14	17	17	17
ISO5211	F03/F04	F03/F04	F04/F05	F04/F05	F05/F07	F05/F07	F07/F010	F07/F010	F07/F010
Z-d1	4-Ø14	4-Ø14	4-Ø14	4-Ø18	4-Ø18	4-Ø18	4-Ø18	8-Ø18	8-Ø18
h	48	53	58.5	71	76.5	85	100	112.5	125.5
s	42.6	42.6	50	50	64.5	64.5	93.6	93.6	93.6
Torque	5	8	10	14	20	30	48	75	110
Kgs	2.91	3.38	3.73	4.95	6.10	8.90	12.8	18.9	26.6

N.	Part Name	Material
1	Cap	CF8M
2	Bolt	Stainless Steel 304
3	Body Gasket	PTFE
4	Body	CF8M
5	Ball	Stainless Steel 316
6	Ball Seat	R-PTFE (15%)
7	Stem	Stainless Steel 316
8	Thrust Washer	PTFE
9	O-Ring	Viton
10	Stem Packing	PTFE
11	Packing Ring	Stainless Steel 304
12	Belleville Washer	Stainless Steel 304
13	Nut Stopper	Stainless Steel 304
14	Plate Washer	Stainless Steel 304
15	Nut	Stainless Steel 304
16	Lock Device	Stainless Steel 304
17	Handle	Stainless Steel 304
18	Plastic Cover	Plastic
19	Stop Pin	Stainless Steel 304

* Torque - Raw torque with no safety added

Technical Data

Max Pressure 40 Bar (1/2"-2") 16 Bar (2 1/2" - 4")
 Working Temperature -25°C to +200°C

Dimensions in mm

This data sheet is designed as a guide and should not be regarded as wholly accurate in every detail. We reserve the right to amend the specification of any product without notice.



PN16 Stainless Steel Flanged Ball Valve

Features

- Flanged PN16
- PTFE/Viton Stem Seals
- RPTFE (15%) Seats
- Full Bore
- ISO 5211 Direct Mount
- Fire Safe Design

Pressure / Temperature

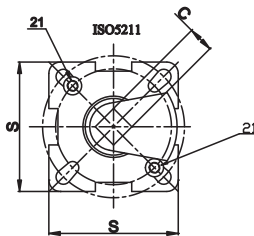
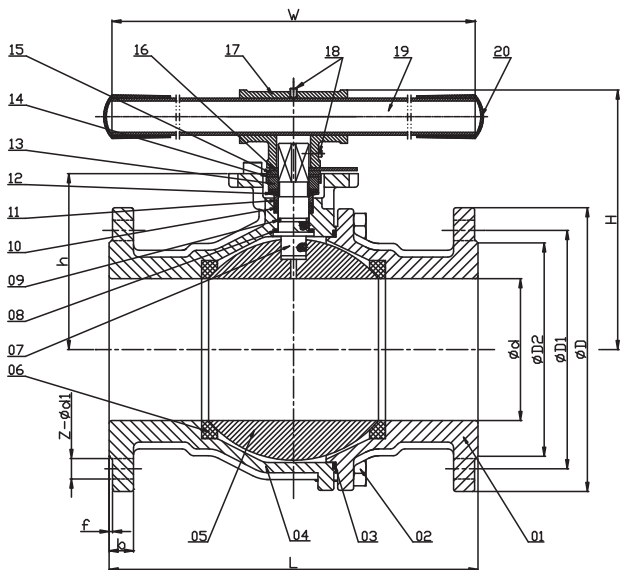
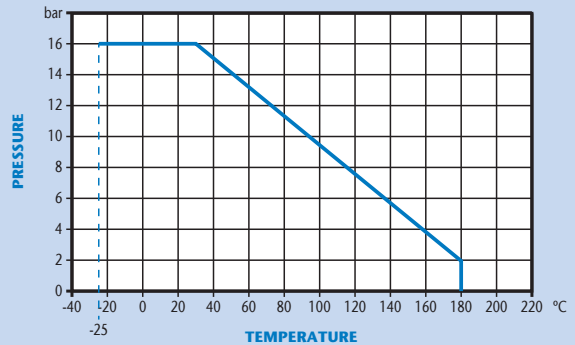

DN	5"	6"	8"
d	125	150	200
L	325	350	400
D	250	285	340
D1	210	240	295
D2	188	212	268
b	22	22	24
f	3	3	3
H	228	246	310
W	600	600	800
C	22	22	27
ISO5211	F10/F12	F10/F12	F12/F14
Z-d1	8-Ø18	8-Ø22	12-Ø22
h	155	172.5	217
s	114	114	131
Torque	200	300	400
Kgs	48.43	65.59	118.17

N.	Part Name	Material
1	Cap	CF8M
2	Bolt	Stainless Steel 304
3	Body Gasket	PTFE
4	Body	CF8M
5	Ball	Stainless Steel 316
6	Ball Seat	R-PTFE (15%)
7	Stem	Stainless Steel 316
8	Thrust Washer	PTFE
9	O-Ring	Viton
10	Stem Packing	PTFE
11	Packing Ring	Stainless Steel 304
12	Belleville Washer	Stainless Steel 301
13	Nut	Stainless Steel 304
14	Nut Stopper	Stainless Steel 304
15	Plate Washer	Stainless Steel 304
16	Lock Device	Stainless Steel 304
17	Sleeve	Stainless Steel 304
18	Jackscrew	Stainless Steel 304
19	Handle	Galvanised Pip
20	Plastic Cover	Plastic
21	Stop Pin	Stainless Steel 304

* Torque - Raw torque with no safety added

Technical Data

Max Pressure 16 Bar
 Working Temperature -25°C to +180°C

Dimensions in mm

This data sheet is designed as a guide and should not be regarded as wholly accurate in every detail. We reserve the right to amend the specification of any product without notice.

ANSI 150 Stainless Steel Flanged Ball Valve

Features

- Flanged ANSI 150
- Class 150 Rated
- RPTFE (15%) Seats
- PTFE/Viton Seals
- Full Bore
- ISO 5211 Direct Mount

Pressure / Temperature

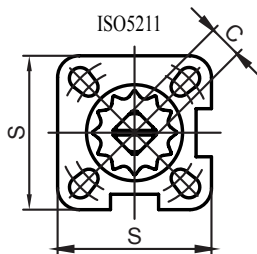
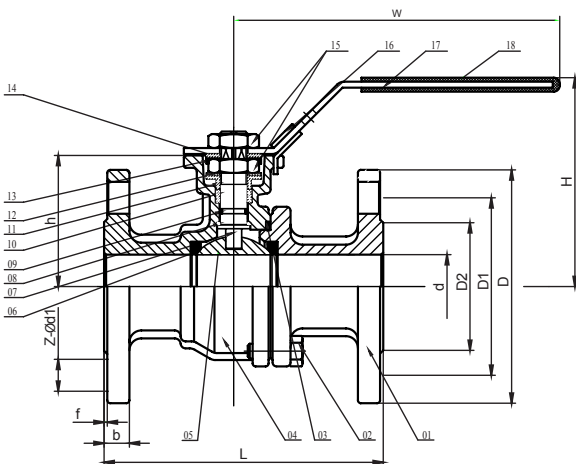
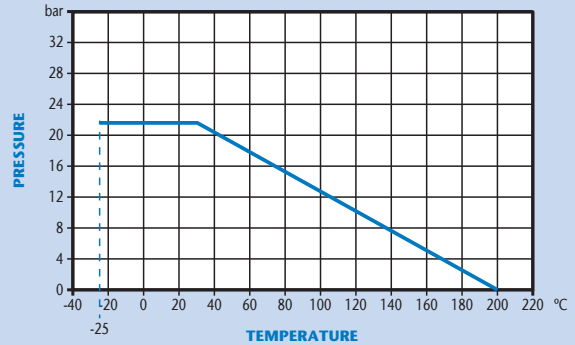

* Torque - Raw torque with no safety added

Technical Data

Max Pressure 22 bar
 Working Temperature -25°C to +200°C

Dimensions in mm

This data sheet is designed as a guide and should not be regarded as wholly accurate in every detail. We reserve the right to amend the specification of any product without notice.

DN	1/2"	3/4"	1"	1 1/4"	1 1/2"	2"	2 1/2"	3"	4"
d	15	20	25	32	38	50	65	76	94
L	108	117	127	140	165	178	190	203	229
D	89	98	108	117	127	152	178	190	229
D1	60.5	70	79.5	89	98.5	120.5	139.5	152.5	190.5
D2	35	43	51	64	73	92	105	127	157
b	10	11	11	13	15	16	18	19	24
f	2	2	2	2	2	2	2	2	2
H	80	85	95	108	114	124	148	158	191
W	140	140	160	160	185	185	230	230	230
C	9	9	11	11	14	14	17	17	17
ISO5211	F03/F04	F03/F04	F04/F05	F04/F05	F05/F07	F05/F07	F07/F010	F07/F010	F07/F010
Z-Ød1	4-Ø16	4-Ø16	4-Ø16	4-Ø16	4-Ø16	4-Ø19	4-Ø19	4-Ø19	8-Ø19
h	48.3	53	58.5	71	76	84.5	101.5	111.5	141
s	42.6	42.6	50	50	64.5	64.5	93.6	93.6	93.6
Torque	5	8	10	14	18	25	48	75	110
Kgs	1.35	1.85	2.60	3.58	5.40	7.95	13.5	17.3	29.5

N.	Part Name	Material
1	Cap	CF8M
2	Bolt	Stainless Steel 304
3	Body Gasket	PTFE
4	Body	CF8M
5	Ball	Stainless Steel 316
6	Ball Seat	R-PTFE (15%)
7	Stem	Stainless Steel 316
8	Thrust Washer	PTFE
9	O-Ring	Viton
10	Stem Packing	PTFE
11	Packing Ring	Stainless Steel 304
12	Belleville Washer	Stainless Steel 301
13	Nut Stopper	Stainless Steel 304
14	Plate Washer	Stainless Steel 304
15	Nut	Stainless Steel 304
16	Lock Device	Stainless Steel 304
17	Handle	Stainless Steel 304
18	Plastic Cover	Plastic
19	Stop Pin	Stainless Steel 304

PN82 Stainless Steel 'T' Port Ball Valve

Features

- Screwed BSP Taper
- RPTFE (15%) Seats
- PTFE/Viton Seals
- Reduced Bore
- PN82 Rated
- Locking Device
- ISO 5211 Direct Mount

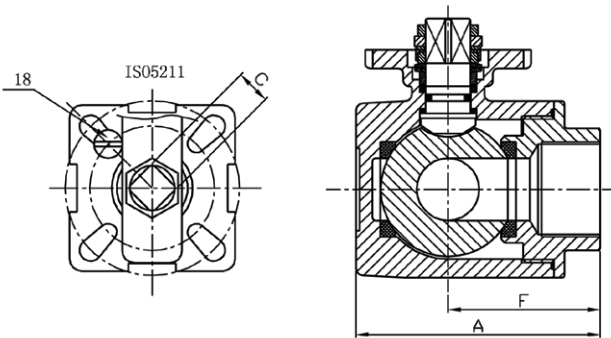
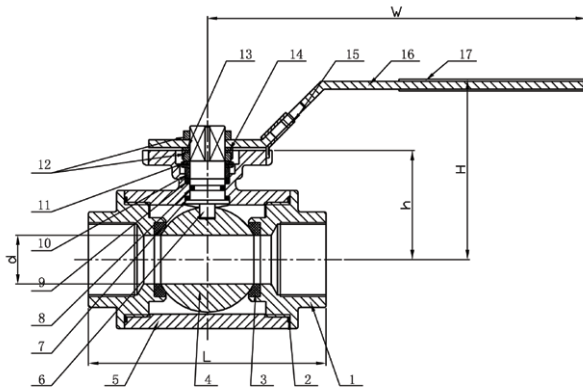

Pressure / Temperature

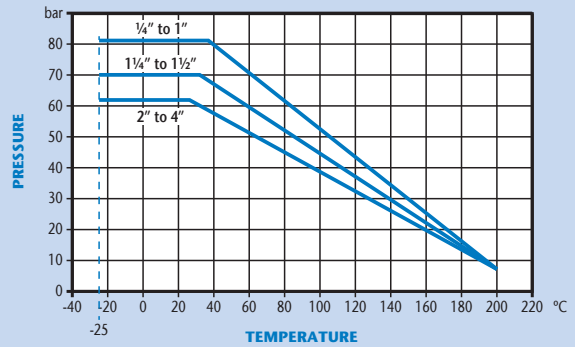

DN	1/4"	3/8"	1/2"	3/4"	1"	1 1/4"	1 1/2"	2"	2 1/2"	3"	4"
d	9.5	11	12	15	20	25	32	40	49	60	75
L	75	75	75	85	100	122	131	158	178	202	246
H	66	66	66	72	77	92	96	107	135	147	160
W	130	130	130	161	161	203	203	203	254	254	310
h	36.8	36.8	36.8	41.2	46.5	56	60	70.5	95.5	106	119
F	37.5	37.5	37.5	42.5	50	61	65.5	79	89	101	123
A	57.5	57.5	57.5	65.5	79	97	106.5	129	145	167	203
C	9	9	9	11	11	14	14	14	17	17	17
ISO5211	F03/F04	F03/F04	F03/F04	F04/F05	F04/F05	F05/F07	F05/F07	F05/F07	F07/F010	F07/F010	F07/F010
Torque	8	8	8	9	15	20	30	45	60	90	120
Kgs	0.70	0.67	0.63	0.94	1.39	2.91	3.66	6.31	8.95	13.11	22.10

N.	Part Name	Material
1	Cap	CF8M
2	Gasket	PTFE
3	Ball Seat	R-PTFE (15%)
4	Ball	Stainless Steel 316
5	Body	CF8M
6	Stem	Stainless Steel 316
7	Thrust Washer	PTFE
8	O-Ring	Viton
9	Stem Packing	PTFE
10	Stem Ring	Stainless Steel 316
11	Belleville Washer	Stainless Steel 304(301)
12	Nut	Stainless Steel 304
13	Plate Washer	Stainless Steel 304
14	Nut Stopper	Stainless Steel 304
15	Lock Device	Stainless Steel 304
16	Handle	Stainless Steel 304
17	Handle Sleeve	Plastic
18	Stop Pin	Stainless Steel 304

* Torque - Raw torque with no safety added

Technical Data

Max Pressure 82 Bar (1/4"-1") 69 Bar (1 1/4"-1 1/2") 62 Bar (2"-4")
 Working Temperature -25°C to +200°C

Dimensions in mm

This data sheet is designed as a guide and should not be regarded as wholly accurate in every detail. We reserve the right to amend the specification of any product without notice.

PN82 Stainless Steel 'L' Port Ball Valve



Features

- Screwed BSP Taper
- RPTFE (15%) Seats
- PTFE/Viton Seals
- Reduced Bore
- PN82 Rated
- Locking Device
- ISO 5211 Direct Mount

Pressure / Temperature

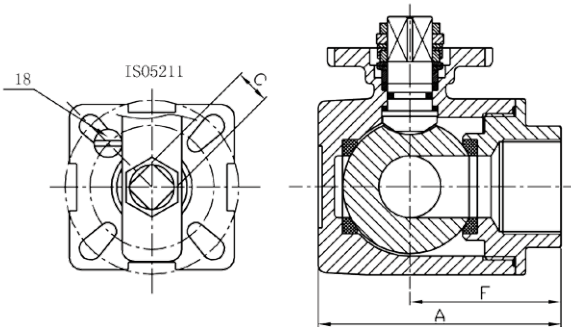
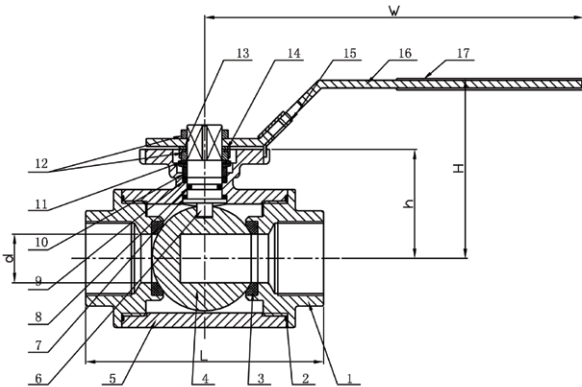
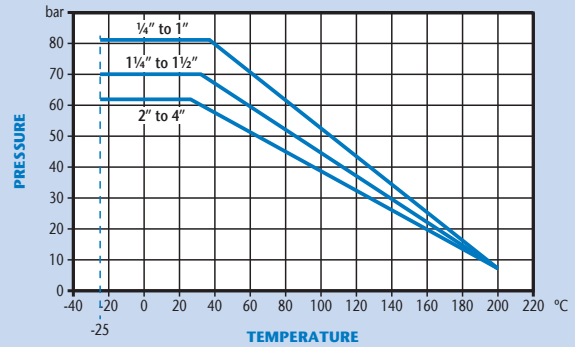

DN	1/4"	3/8"	1/2"	3/4"	1"	1 1/4"	1 1/2"	2"	2 1/2"	3"	4"
d	9.5	11	12	15	20	25	32	40	49	60	75
L	75	75	75	85	100	122	131	158	178	202	246
H	66	66	66	72	77	92	96	107	135	147	160
W	130	130	130	161	161	203	203	203	254	254	310
h	36.8	36.8	36.8	41.2	46.5	56	60	70.5	95.5	106	119
F	37.5	37.5	37.5	42.5	50	61	65.5	79	89	101	123
A	57.5	57.5	57.5	65.5	79	97	106.5	129	145	167	203
C	9	9	9	11	11	14	14	14	17	17	17
ISO5211	F03/F04	F03/F04	F03/F04	F04/F05	F04/F05	F05/F07	F05/F07	F05/F07	F07/F010	F07/F010	F07/F010
Torque	8	8	8	9	15	20	30	45	60	90	120
Kgs	0.70	0.67	0.63	0.94	1.39	2.91	3.66	6.31	8.95	13.11	22.10

N.	Part Name	Material
1	Cap	CF8M
2	Gasket	PTFE
3	Ball Seat	R-PTFE (15%)
4	Ball	Stainless Steel 316
5	Body	CF8M
6	Stem	Stainless Steel 316
7	Thrust Washer	PTFE
8	O-Ring	Viton
9	Stem Packing	PTFE
10	Stem Ring	Stainless Steel 316
11	Belleville Washer	Stainless Steel 304(301)
12	Nut	Stainless Steel 304
13	Plate Washer	Stainless Steel 304
14	Nut Stopper	Stainless Steel 304
15	Lock Device	Stainless Steel 304
16	Handle	Stainless Steel 304
17	Handle Sleeve	Plastic
18	Stop Pin	Stainless Steel 304

* Torque - Raw torque with no safety added

Technical Data

Max Pressure 82 Bar (1/4"-1") 69 Bar (1 1/4"-1 1/2") 62 Bar (2"-4")
 Working Temperature -25°C to +200°C

Dimensions in mm

This data sheet is designed as a guide and should not be regarded as wholly accurate in every detail. We reserve the right to amend the specification of any product without notice.

PN16 Stainless Steel Gate Valve

Features

- Screwed BSP Parallel
- PTFE Seals
- Full Bore
- PN16 Rated



Pressure / Temperature

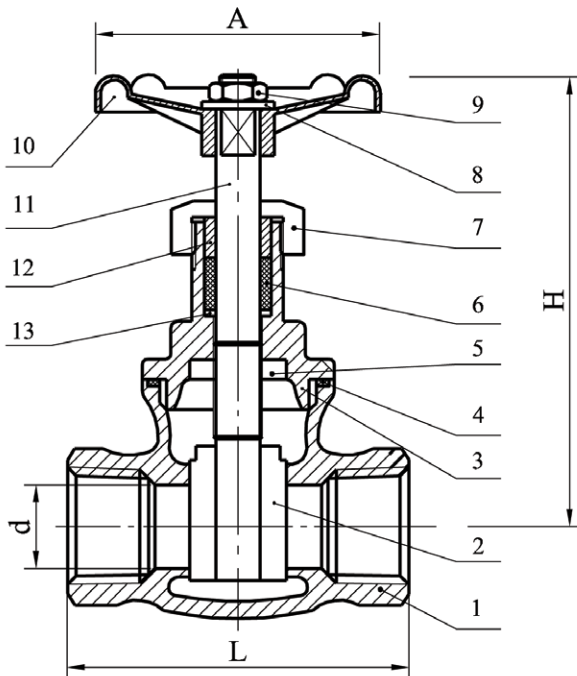
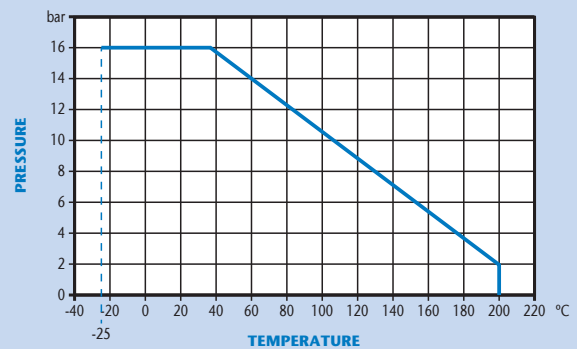

DN	1/4"	3/8"	1/2"	3/4"	1"	1 1/4"	1 1/2"	2"
d	10	12	15	20	25	32	40	50
L	55	55	55	60	65	73	76	85
H	98	98	98	104	115	125	137	160
A	66	66	66	72	72	97	97	108
Kgs	0.42	0.42	0.41	0.53	0.69	0.99	1.31	1.85

Technical Data

Max Pressure 16 Bar
 Working Temperature -25°C to +200°C

N.	Part Name	Material
1	Body	CF8M
2	Disc	CF8M
3	Bonnet	CF8M
4	Gasket	PTFE
5	Snap Washer	Stainless Steel 316
6	Packing	PTFE
7	Packing Nut	Stainless Steel 316
8	Washer	Stainless Steel 304
9	Wheel Nut	Stainless Steel 304
10	Hand Wheel	Aluminium Alloy
11	Stem	Stainless Steel 316
12	Gland	Stainless Steel 304
13	Snap Washer	Stainless Steel 304

Dimensions in mm

This data sheet is designed as a guide and should not be regarded as wholly accurate in every detail. We reserve the right to amend the specification of any product without notice.

PN16 Stainless Steel Globe Valve

Features

- Screwed BSP Parallel
- PTFE Seals
- Metal Seat
- PN16 Rated



Pressure / Temperature

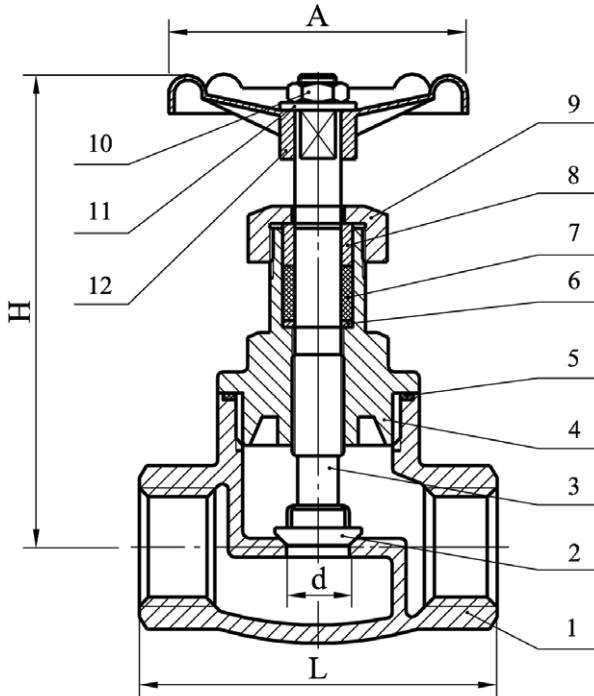
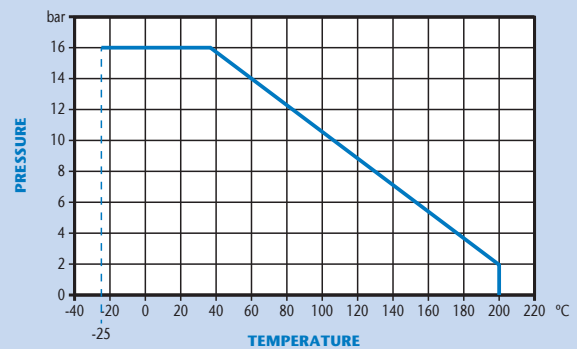

DN	1/4"	3/8"	1/2"	3/4"	1"	1 1/4"	1 1/2"	2"
d	10	12	15	20	25	32	40	50
L	67	67	67	80	89	100	118	134
H	79	79	79	91	106	125	136	146
A	66	66	66	71	77	90	105	105
Kgs	0.42	0.42	0.40	0.57	0.80	1.30	1.84	2.40

Technical Data

Max Pressure 16 Bar
 Working Temperature -25°C to +200°C

N.	Part Name	Material
1	Body	CF8M
2	Petal	Stainless Steel 316
3	Stem	Stainless Steel 316
4	Cap	CF8M
5	Gasket	PTFE
6	Washer	Stainless Steel 304
7	Stem Packing	PTFE
8	Ring	Stainless Steel 304
9	Gland Ring	Stainless Steel 304
10	Wheel Nut	Stainless Steel 304
11	Plate	Stainless Steel 304
12	Hand Wheel	Aluminium Alloy

Dimensions in mm

This data sheet is designed as a guide and should not be regarded as wholly accurate in every detail. We reserve the right to amend the specification of any product without notice.

PN16 Stainless Steel Wafer Check Valve

Features

- Wafer Pattern to suit PN16 & ASA ISO Flanges
- Viton Seats & Seals
- Suitable for Upwards or Horizontal Flow
- PN16 Rated

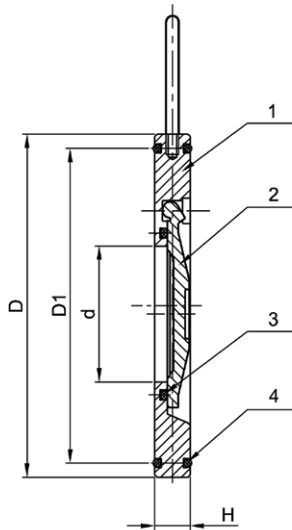
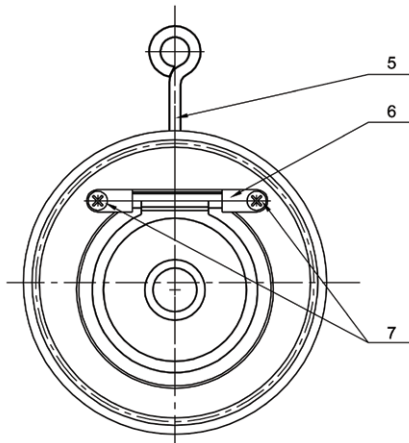

Technical Data

Max Pressure 16 Bar
 Working Temperature -25°C to +200°C

Pressure / Temperature

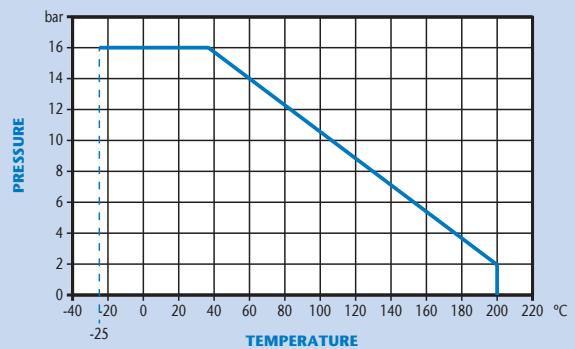

DN	2"	2 1/2"	3"	4"	5"	6"	8"	10"	12"
d	32	40	54	70	92	114	154	200	230
D	105	124	136	164	194	220	275	330	384
D1	84	96	117.5	148	166	197	249	310	358
H	14	14	14	18	18	20	22	26	30
Kgs	0.85	1.15	1.34	2.30	3.10	4.40	7.10	12.0	20.5

N.	Part Name	Material
1	Body	CF8M
2	Disc	CF8M
3	Disc O'ring	Viton
4	External O'ring	Viton
5	Hook	Steel
6	Stem Stopper	Stainless Steel 316
7	Axis Screw	Stainless Steel 316

Dimensions in mm

This data sheet is designed as a guide and should not be regarded as wholly accurate in every detail. We reserve the right to amend the specification of any product without notice.



PN40 Stainless Steel Wafer Spring Check Valve

Features

- Wafer Pattern to suit PN10,16,40 & ANSI 150, 300 Flanges
- Metal Seat
- PN40 Rated

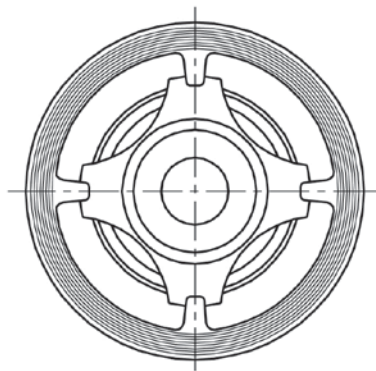
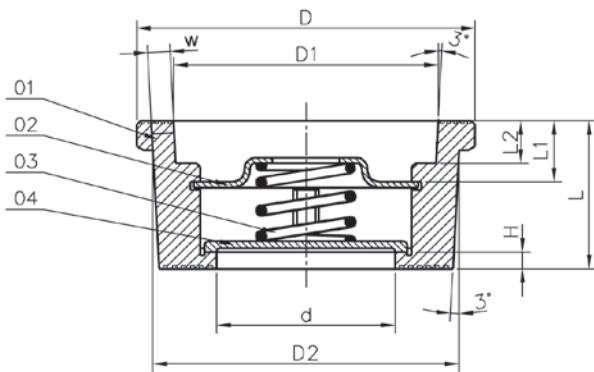

Pressure / Temperature

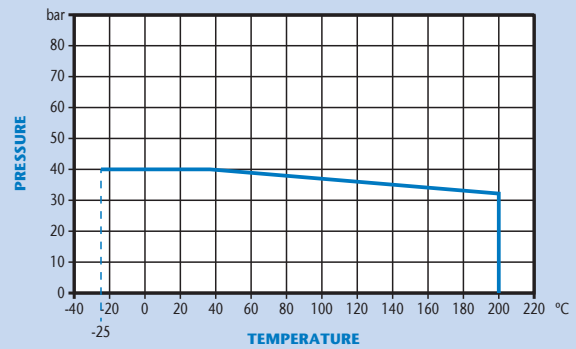

DN	1/2"	3/4"	1"	1 1/4"	1 1/2"	2"	2 1/2"	3"	4"
d	15	20	25	32	40	48	62	75	95
D	39	46	54	70	81	94	113	132	150
D1	28.3	35.7	40	52.4	61	75.4	90	109	125.3
D2	34	41	49	62	71	85	102	123	140
W	3.1	3.3	4.5	4.8	5	5.3	6	7	7.5
L	16	19	22	28	32	40	46	50	60
L1	4	5	5.5	8	10	15	17.5	18	23
L2	2	2	3	4	4	4	5	5	6
H	3.5	4	4	5	5.5	6	6.5	7.5	8.5
Kgs	0.10	0.14	0.22	0.39	0.54	0.77	1.25	1.90	2.80

Technical Data

Max Pressure 40 Bar
 Working Temperature -25°C to +200°C

N.	Part Name	Material
1	Body	CF8M
2	Spring Cover	Stainless Steel 316
3	Spring	Stainless Steel 316
4	Disc	CF8M

Dimensions in mm

This data sheet is designed as a guide and should not be regarded as wholly accurate in every detail. We reserve the right to amend the specification of any product without notice.

PN16 Stainless Steel Swing Check Valve

Features

- Screwed BSP Parallel
- Metal Seat
- PTFE Joint Gasket



Pressure / Temperature

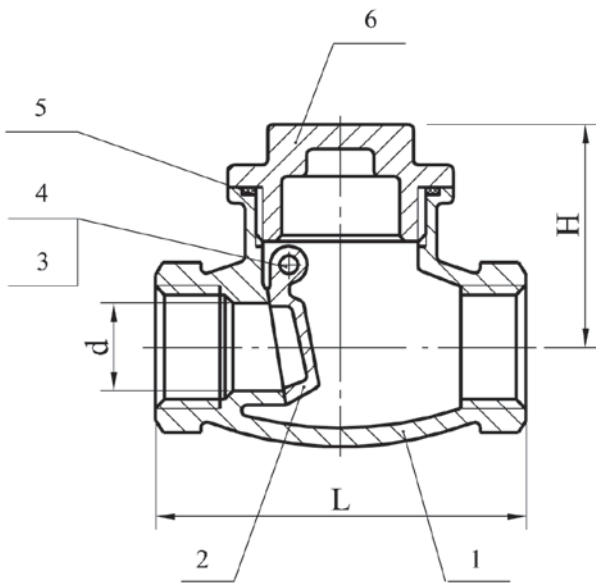
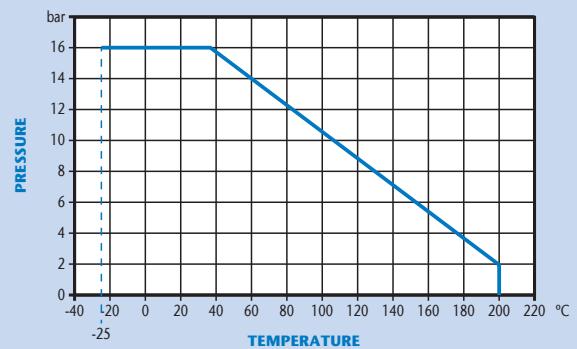

DN	1/4"	3/8"	1/2"	3/4"	1"	1 1/4"	1 1/2"	2"
d	10	12	15	20	25	32	40	50
L	63	63	63	78	87	101	115	135
H	42	42	42	46	50	54	64	71
Kgs	0.27	0.26	0.25	0.34	0.47	0.76	1.03	1.45

Technical Data

Max Pressure 16 Bar
 Working Temperature -25°C to +200°C

N.	Part Name	Material
1	Body	CF8M
2	Disc	CF8M
3	Pipe Plug	Stainless Steel 316
4	Plug Gasket	PTFE
5	Body Gasket	PTFE
6	Cap	CF8M

Dimensions in mm

This data sheet is designed as a guide and should not be regarded as wholly accurate in every detail. We reserve the right to amend the specification of any product without notice.

PN82 Stainless Steel Spring Check Valve

Features

- Screwed BSP Parallel
- Metal Seat
- PTFE Seals
- 316 Stainless Steel Spring



Pressure / Temperature

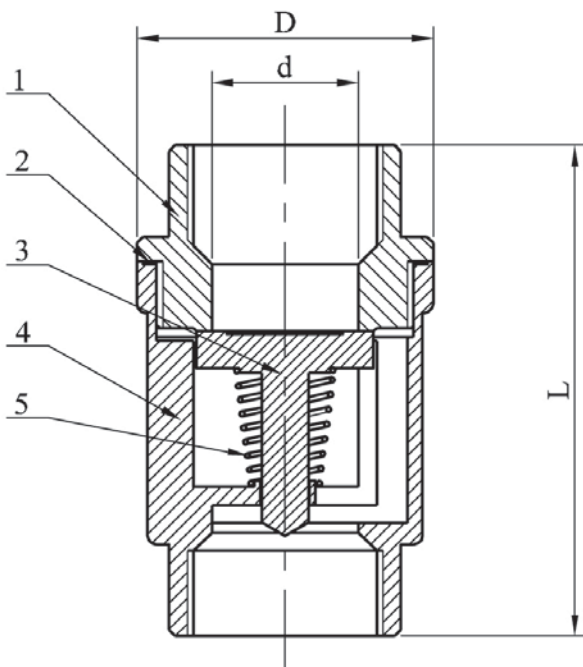
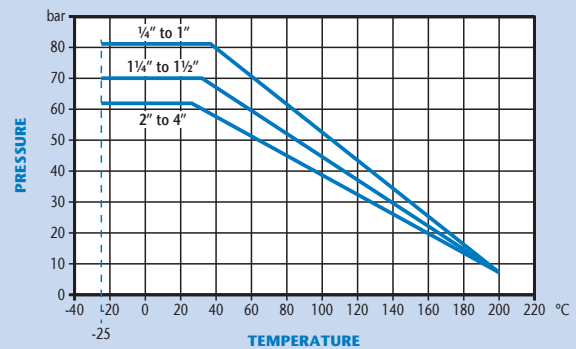

Technical Data

Max Pressure 82 Bar (1/4"-1") 69 Bar (1 1/4"-1 1/2") 62 Bar (2"-4")
 Working Temperature -25°C to +200°C

DN	1/4"	3/8"	1/2"	3/4"	1"	1 1/4"	1 1/2"	2"	2 1/2"	3"	4"
d	8	10	15	20	25	30	38	47	61	75	94
D	30.5	30.5	37	42	48	58	70	82	102.5	120	150
L	53	53	56	63	74	81	91	97	118	138	158
Kgs	0.18	0.17	0.21	0.29	0.40	0.65	0.98	1.40	2.44	3.80	6.60

N.	Part Name	Material
1	Cap	CF8M
2	Body Gasket	PTFE
3	Disc	CF8M
4	Body	CF8M
5	Spring	Stainless Steel 316

Dimensions in mm

This data sheet is designed as a guide and should not be regarded as wholly accurate in every detail. We reserve the right to amend the specification of any product without notice.

PN55 Stainless Steel Screwed 'Y' Type Strainer

Features

- Screwed BSP Parallel
- 1mm/1000 micron mesh
- PTFE Joint Gasket
- Body CF8M

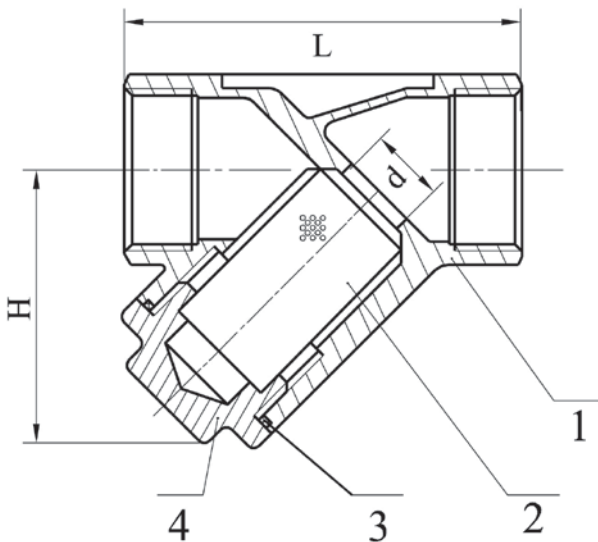
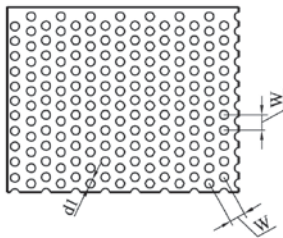

Pressure / Temperature

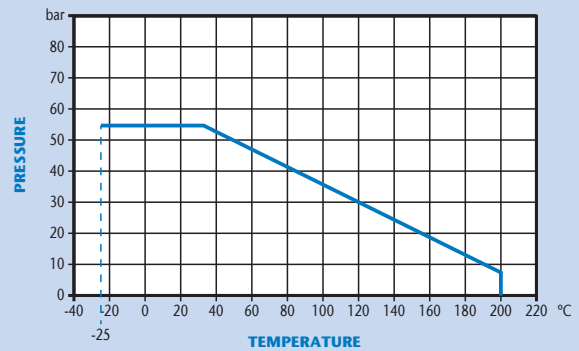

DN	1/4"	3/8"	1/2"	3/4"	1"	1 1/4"	1 1/2"	2"	2 1/2"	3"	4"
d	10	12	15	20	25	32	38	50	61	75	94
L	64	64	64	80	90	106	119	140	167	198	238
H	43	43	45	52	68	70	80	98	117	137	163
W	2	2	2	2	2	2	2	2	2	2	2
d1	1	1	1	1	1	1	1	1	1	1	1
Kgs	0.20	0.20	0.21	0.34	0.59	0.80	1.06	1.61	2.99	4.74	7.88

Technical Data

Max Pressure 55 Bar
Working Temperature -25°C to +200°C

N.	Part Name	Material
1	Body	CF8M
2	Screen	Stainless Steel 316
3	Joint Gasket	PTFE
4	Bonnet	CF8M

Dimensions in mm

This data sheet is designed as a guide and should not be regarded as wholly accurate in every detail. We reserve the right to amend the specification of any product without notice.

PN16 Stainless Steel Flanged 'Y' Type Strainer

Features

- Flanged PN16
- Mesh 1mm (Up to 2"), 2mm (2 1/2"-4")
- PTFE Joint Gasket
- Body CF8M

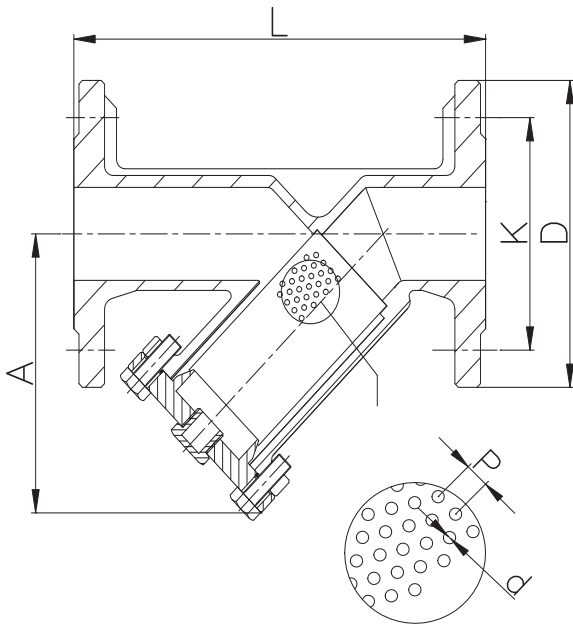
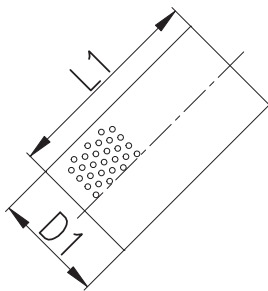
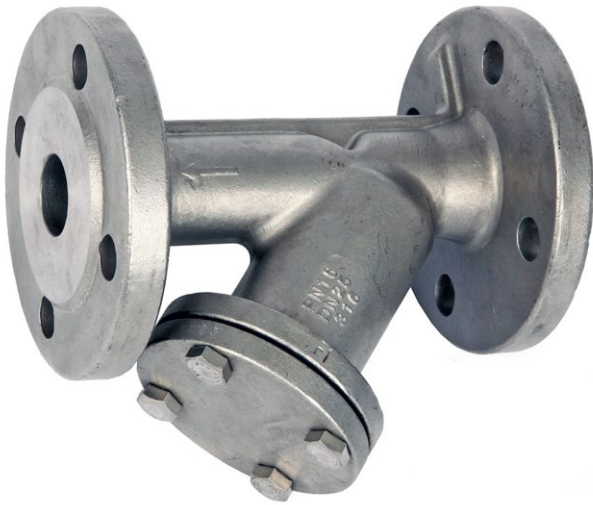

Pressure / Temperature

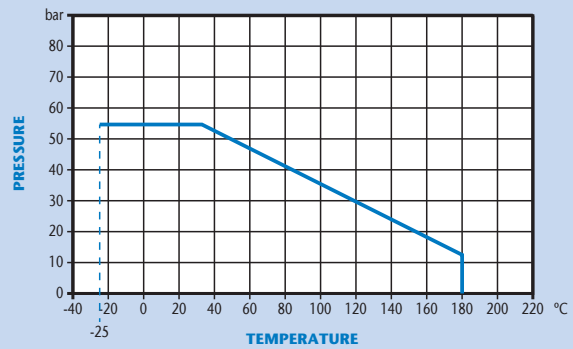

DN	1/2"	3/4"	1"	1 1/4"	1 1/2"	2"	2 1/2"	3"	4"
A	75	90	100	115	130	150	190	225	230
D	95	105	115	140	150	165	185	200	220
D1	22	26	32	37	47	57	69	84	105
L	130	150	160	180	200	230	290	310	350
L1	58	65	72	83	95	114	152	176	180
P	2	2	2	2	2	2	3.5	3.5	3.5
d	1	1	1	1	1	1	2	2	2
K	65	75	85	100	110	125	145	160	160

Technical Data

Max Pressure 55 Bar
 Working Temperature -25°C to +180°C

N.	Part Name	Material
1	Body	CF8M
2	Cover	CF8M
3	Bolt	Stainless Steel 304
4	Joint Gasket	PTFE
5	Filter Screen	CF8M
6	Blow Off Plug	CF8M

Dimensions in mm

This data sheet is designed as a guide and should not be regarded as wholly accurate in every detail. We reserve the right to amend the specification of any product without notice.



Certificate No. 1437B



Certificate No. 1437A

Distributor